

1 2 3 4 5 6

A

B

C

A

B

C

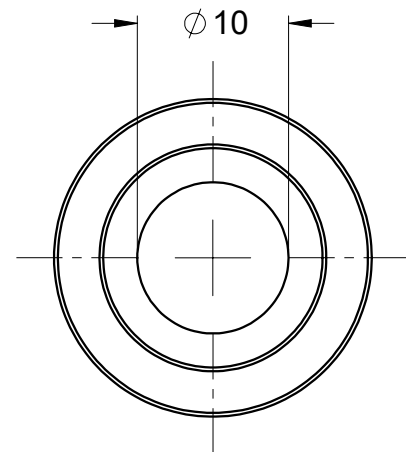
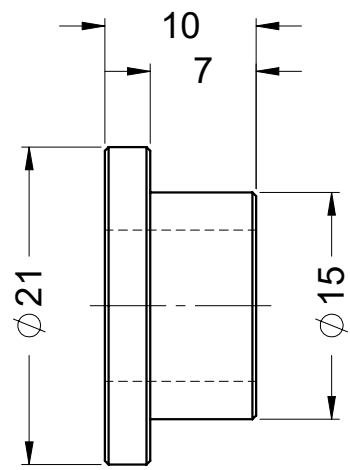

SUPPLIER - OILITE
SUPPLIER PART No - AL1015



UNIT OF MEASURE: MILLIMETRES	UNTOLERANCED DIMENSIONS: GENL. ±0.20 FAB. ±1.00 CAST. ±3.00 ANGLES ±0.5° SURFACE FINISH 3.2µm	PART No. 23B01M101510	THIRD ANGLE	DO NOT SCALE - IF IN DOUBT ASK.
------------------------------	---	------------------------------	--------------------	---------------------------------

UK MATERIAL: Phosphor Bronze BS EN 1982 CC481K (PB1-C)			THIS DRAWING AND THE INFORMATION IT CONTAINS IS THE PROPERTY OF BW FLEXIBLE SYSTEMS. THIS DRAWING IS LOANED STRICTLY ON CONDITION THAT IT WILL NOT BE REPRODUCED OR COPIED IN ANY MANNER. THAT IT WILL BE RETURNED TO THE OWNER IMMEDIATELY ON DEMAND. THAT IT WILL NOT BE COMMUNICATED TO ANY THIRD PARTY AND THAT THE INFORMATION IT CONTAINS WILL BE USED SOLELY IN CONNECTION WITH WORK BEING PERFORMED AND OR SPECIFICALLY AUTHORISED IN WRITING BY FLEXIBLE SYSTEMS.	
FINISH DESCR.: No Finish				

D

23 Beeston Business Park Technology Drive Beeston, Nottingham, NG9 1LA, England Telephone: +44 115 967 8787	Via Trieste, 53 Mestrino, Padua, Italy. Telephone: +39 049 9006511
225, Spartangreen Blvd, Duncan, South Carolina, 29334 U.S.A Telephone: +01 864 486 4000	Viale del Lavoro, 9, 36030 Monte di malo VI, Italy Telephone: +39 0445 602 300

US FINISH NO.: 000	UK FINISH NO.: 000	DRAWN BY: D. FREEMAN	DATE:	SHEET 1 OF 1
DESCRIPTION OILITE BUSH			DRAWING No. 23B01M101510	REV 0

1 2 3 4 5 6

MODEL FILE:C:\HayssenSandiacre\NOTTINGHAM\SolidWorks Library\23123B123B01M101510